

Cost Analysis of Use of Tranexamic Acid to Prevent Major Bleeding Complications in Hip and Knee Arthroplasty Surgery

James Slover, MD, MS, and Joseph Bosco, MD

Abstract

We used decision analysis to assess the cost profile associated with preoperative use of tranexamic acid (TXA) to prevent major bleeding complications associated with hip and knee arthroplasty surgery. We defined major bleeding complications as blood loss sufficient to require transfusion or surgical evacuation of a postoperative hematoma.

In the absence of a reduction in revision rates, using current cost data, TXA use is not cost-saving for institu-

tions with baseline blood transfusion rates under 25%. For centers with baseline transfusion rates above 25%, however, TXA becomes increasingly cost-saving as the reduction in transfusion rates seen with use of the drug increases, but a minimum 12% reduction in transfusion rates is needed, even if the expected baseline transfusion rate is 100%. Nevertheless, TXA use is much more likely to be cost-saving, regardless of transfusion rates, if it leads to a reduction in need for revision surgery.

Arthroplasty procedures are common, and their use is projected to increase rapidly over the next 25 years. According to Kurtz and colleagues,¹ approximately 658,000 primary joint replacements were performed in the United States in 2005. With this number projected to rise to approximately 4 million by 2030,² the associated costs must be reduced in order to preserve access to and adequate funding for these procedures. Blood transfusion is needed relatively often after total knee arthroplasties. Transfusion rates vary significantly in the literature and in practice, with rates as high as 70% and as low as 1% reported.^{3,4} Blood transfusion is associated with a number of potentially negative outcomes, including allergic reactions and immune-modulating effects that can increase infection rates; increased pain; and decreased range of motion. Transfusions also add significant cost to the overall episode of care.⁵⁻⁷ In addition, excessive bleeding can require surgical evacuation, which can result in significant morbidity and substantial cost.⁸

Efforts to reduce blood loss and the need for transfusion or revision have been undertaken to improve patient outcomes and save costs. Tranexamic acid (TXA) is an antifibrinolytic agent that prevents dissolution of blood clots. Despite significant heterogeneity, numerous studies have explored use of TXA to reduce

blood loss after joint replacement surgery.⁹⁻¹⁴ These studies have demonstrated that TXA decreases transfusion rates, and many have adopted its use, but a reduction in revision rates has not been demonstrated.

We conducted a study to analyze the cost profile of routine use of TXA in order to determine the specific conditions (trans-

Figure 1. Markov model used to model patients with end-stage knee arthritis treated with total knee arthroplasty using either perioperative tranexamic acid (TXA) or no TXA. Each patient undergoes total knee arthroplasty and, if required, receives transfusion. Each group undergoes revision or does not, according to model probabilities (reviewed in Materials and Methods section).

Abbreviations: TJA, total joint arthroplasty; TXA, tranexamic acid.

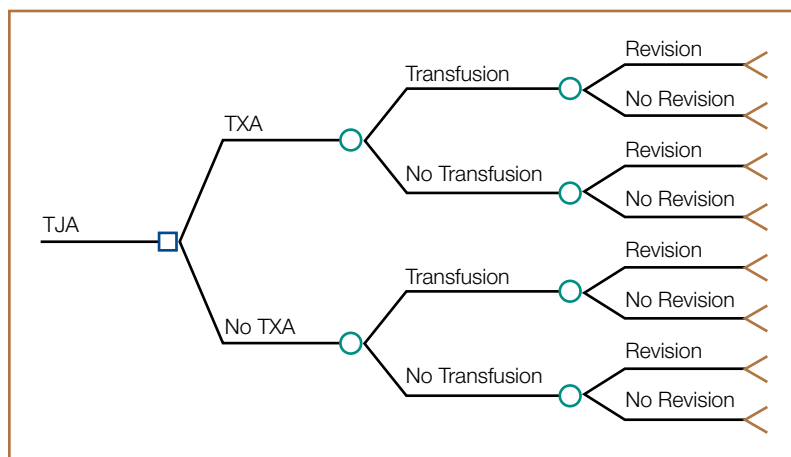

Authors' Disclosure Statement: The authors report no actual or potential conflict of interest in relation to this article.

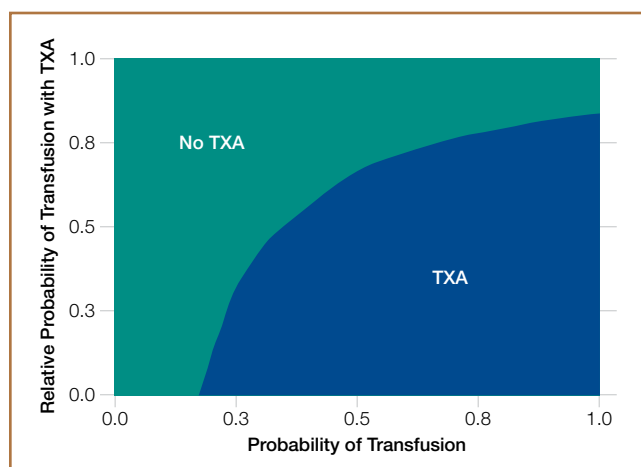

Figure 2. Two-way sensitivity analysis results. Baseline transfusion rate without use of tranexamic acid (TXA) is shown on x-axis; relative transfusion rate with TXA use is shown on y-axis. Blue areas indicate profiles for which routine TXA use is cost-saving; green areas indicate profiles for which routine TXA use is not cost-saving.

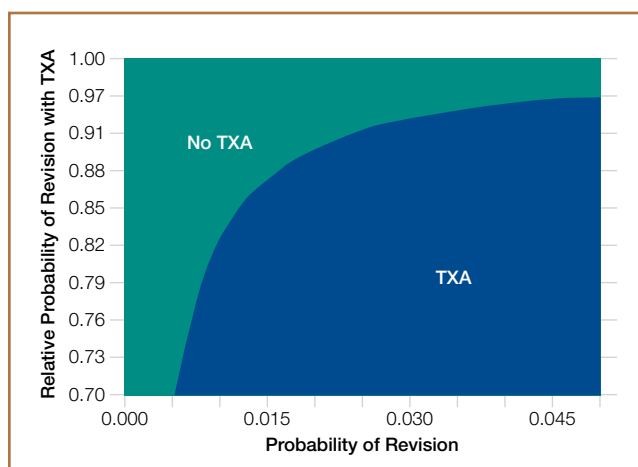

Figure 3. Two-way sensitivity analysis results. Baseline revision rate for evacuation of hematoma is shown on x-axis; relative revision rate with use of tranexamic acid (TXA) is shown on y-axis. Blue areas indicate profiles for which routine TXA use is cost-saving; green areas indicate profiles for which routine TXA use is not cost-saving. Higher reduction or lower relative revision rates with TXA translate into cost savings.

fusion rates) under which it would be cost-saving.

Materials and Methods

We constructed a Markov decision model¹⁵ to evaluate the impact of any effect of TXA use on blood transfusion rates on the cost of hip and knee arthroplasty procedures. The impact of any secondary effect on revisions on the cost was also assessed with the model. The decision model depicting the pathway taken by patients in the screening program is shown in **Figure 1**. Patients transition along the appropriate arm of the decision tree according to the likelihood of each event (determined by the probability of each event in the literature). In addition, cost is assigned to every treatment within the model.

The cost of TXA treatment and blood transfusion was taken from charge data at our institution. We use a protocol of two 1-g intravenous doses, the first given before incision and the second at start of closure. Using these charge data, we set the cost of TXA at \$64 per case. The cost of blood transfusion was set at \$380 based on literature-reported costs in the model.¹⁶ The cost of a revision for evacuation of a postoperative hematoma was estimated to be \$25,000, slightly lower than the estimated resource use for an aseptic revision, given its likelihood of occurring within the index admission and the possibility of avoiding any hardware changes.⁸

After constructing the model, we used the total tabulated costs to ascertain the impact on overall cost with use of TXA to prevent the need for blood transfusion. Sensitivity analysis, a test of the stability of conclusions, is performed by varying a variable or variables over a stated range and evaluating the effect of this variation on the outcome—in this study, the total cost of a patient’s treatment.¹⁵ Two-way sensitivity analysis was performed to examine the relationship between the impact on blood transfusion rates and the transfusion rate reduction

needed to make the program cost-saving and to examine the impact of any secondary effect on revisions on cost. The model was constructed using TreeAge Pro 2007 (TreeAge Software, Williamstown, Massachusetts) decision analysis software.

Results

The relationship between baseline transfusion rates and cost savings for hip and knee replacements is depicted in **Figure 2**, which illustrates the results of a 2-way sensitivity analysis in which the relative impact on transfusion rates with TXA use is varied on the y-axis and the baseline transfusion rate without TXA use is varied on the x-axis, under the condition that no revisions are prevented with TXA use. Blue areas indicate where it would be cost-saving to use TXA before hip and knee replacement, and green areas indicate where TXA use would not be cost-saving. For example, if the baseline transfusion rate with hip and knee replacement is 30%, and TXA use results in a relative reduction in transfusion of 40% or better of the baseline ($\geq 60\%$ reduction), then it is cost-saving to use the drug (blue area). However, the same baseline transfusion rate combined with a relative reduction in transfusion of less than 60% (relative transfusion rate, $\geq 40\%$) would not make TXA use cost-saving (green area). The results demonstrate that, if the baseline transfusion rate is less than 25%, then routine use of TXA to reduce blood transfusion will not be cost-saving unless it reduces the revision rate, even if it eliminates all blood transfusions completely (100% reduction, or relative transfusion rate of 0%).

The second issue studied with the model is how the revision rates and the impact of TXA use on revision rates impact the potential cost savings of TXA for the procedure (**Figure 3**). Different potential probabilities for revision for hematoma, varying from a low of 0.0% to a high of 0.5%, are modeled on the x-axis. A relative reduction in revisions—expressed as

a percentage of the baseline rate so that a relative revision rate of 0.9% represents a 10% reduction in the revision rate with TXA use—is modeled on the y-axis. Combinations in which TXA use would be cost-saving are in blue. The results show that even a modest reduction in revision rates will make routine TXA use cost-saving, with risk for revision for hematoma between 0.0% and 0.5%.

Discussion

The cost associated with hip and knee arthroplasty is a major focus of interest among health care payers. In today's health care environment, in which resources are increasingly limited, the incremental cost benefit of any procedure or medication must be established. This is important from the point of view of both society and payer (overall support for these services is limited). Ensuring access for all who need these procedures, which improve quality of life, depends on the ability to deliver them at the minimum possible total cost—without having any detrimental effect on quality or outcome—and mandates careful consideration of any protocol change, regardless of how inexpensive it may seem. In addition, the care episode is important from the point of view of the hospital, which faces new payment structures in which the hospital is responsible for all care before surgery and for all care for 30 to 90 days after surgery.¹⁷ In this scenario, the more cost-effective the care, the higher the profit margin associated with these procedures.

Decreased bleeding may lead to lower rates of hematoma formation, which can impact therapy, range of motion, and wound healing and reduce the need for potential surgical evacuation.⁶ The need to reduce revision surgery, which may result in significant morbidity and which adds substantial cost to the care episode, is self-evident. Furthermore, a reduction in blood transfusion rates can also benefit patient outcomes by limiting adverse transfusion reactions, which can have a significant clinical impact, and by limiting potential immunomodulating effects, which may increase infection rates.⁵ In addition, blood transfusion is associated with significant costs.¹⁸

Even if it had no impact on blood transfusion or revision rates, TXA use could lead to improved outcomes by decreasing pain and improving postoperative therapy. However, long-term patient-reported outcome data would be needed to evaluate whether TXA use could positively affect outcomes—patients who received TXA and those who did not would have to be compared—and our model did not do this. In addition, TXA use may lead to less blood loss without affecting transfusion rates, and this may also benefit patient recovery. Consequently, routine TXA use potentially can be considered for many reasons, but its impact on cost is an important variable to be evaluated in today's health care environment.

The antifibrinolytic properties of TXA used perioperatively have been shown to decrease blood transfusion rates without increasing thrombotic events. However, the impact on cost and revision rates and other clinical outcomes remains to be clearly defined.^{10,11} There are numerous other potential strategies, such as transfusion algorithms, that have been successfully used to reduce blood transfusion rates.⁴ Therefore, a simple demon-

stration that TXA use can reduce the rate of blood transfusion is not sufficient evidence that it is the best or most cost-effective way to address the issue of blood transfusion after total joint replacement, or that it is cost-saving. However, the evidence that perioperative TXA use reduces blood transfusion rates warrants careful consideration and cost analysis given the potential benefits of decreasing blood loss and transfusion rates after hip and knee replacement. In addition, there may be other benefits that make the cost investment worthwhile. More important, if clear evidence that it reduces revision rates can be demonstrated, it is much more likely to be cost-saving.

This study demonstrates the potential cost savings associated with use of TXA to reduce bleeding in association with elective hip and knee arthroplasty. As expected, the larger the impact of TXA on transfusion or revision rates, the more likely its use is cost-saving. Even if it cannot be demonstrated to reduce revisions for hematoma evacuation, it can still be cost-saving under the right conditions. Furthermore, the impact needed to make it cost-saving decreases as the baseline transfusion rates without TXA use increase. The higher the baseline rate, the lower the impact TXA needs to have in order for it to be cost-saving. Specifically, if the baseline transfusion rate is 30%, then a 60% reduction is needed (relative transfusion rate, 0.4) for routine TXA use to be cost-saving (Figure 2). This decreases to 12% (relative transfusion rate, 0.88) if the baseline rate is 100%. If the baseline transfusion rate is less than 25%, then routine TXA use will not be cost-saving.

The findings of this analysis illustrate several important points of consideration that are often lacking in clinical studies. Although a positive finding, such as a relative risk reduction for a complication, associated with a new or variable intervention, is certainly important, it does not alone provide sufficient evidence that the intervention should be universally adopted or that it will be cost-saving. This determination depends on the magnitude of the problem being addressed both in terms of volume and clinical significance to the patient. In this case, if no clear evidence is found for reduced revisions or improved clinical parameters other than blood transfusion, TXA will be cost-saving only if it reduces transfusions and the baseline rate of blood transfusion is larger than 25%. This demonstrates that the baseline value of a problem needs to be carefully considered when evaluating a new or variable intervention for a clinical problem from a cost perspective. However, if any decrease in revisions for evacuation of hematoma is found, then TXA use is much more likely to be cost-saving (Figure 3). To date, this has not been shown, but centers may still consider its use alone or as part of a multimodal approach if superior clinical outcomes, such as decreased postoperative pain or improved range of motion, can be demonstrated. Studies showing clear improvement in these parameters or revision surgery with TXA use are still needed. Therefore, until clear evidence of that becomes available, centers considering routine TXA use should consider their baseline transfusion rate carefully and monitor the impact of its use on transfusion rates and other patient outcomes to determine the impact on cost in their specific clinical environment.

There are limitations to this analysis. We included only direct costs of the treatment interventions in the analyses. This underestimates the true cost to patients and society in terms of lost earnings and further care needed outside the acute-care setting. Further, we estimated the cost of treatment using charges, and the true cost of these treatments may vary. In addition, blood transfusion or revision may significantly impact patient outcomes, and further study measuring these outcomes is needed to further evaluate the potential cost-effectiveness of this treatment.

Conclusion

The decision analysis model demonstrates that use of TXA to reduce blood transfusion needs with hip and knee arthroplasty may be cost-saving but not in all circumstances. The impact on major bleeding leading to revision or transfusion and the baseline blood transfusion rate are important parameters to understand when evaluating the potential cost savings of routine TXA use. Even a modest reduction in revision rates will make TXA very likely to be cost-saving, but cost savings from a reduction in transfusion rates will occur only if the baseline transfusion rates are above threshold levels for the reduction found. TXA is likely to be used as part of a multimodal approach to reducing blood loss, and careful study of long-term patient outcome data is needed to determine if it leads to improvement of other patient outcomes that would make it more cost-effective regardless of impact on transfusion rates. Studies designed to evaluate this are needed.

Dr. Slover is Assistant Professor, Department of Orthopaedic Surgery, and Dr. Bosco is Vice Chair of Clinical Affairs, New York University Langone Medical Center, New York, New York.

Address correspondence to: James Slover, MD, MS, Department of Orthopaedic Surgery, New York University Langone Medical Center, 301 E 17th St, New York, NY 10003 (tel, 212-598-6146; fax, 212-598-7609; e-mail, james.slover@nyumc.org).

Am J Orthop. 2014;43(10):E217-E220. Copyright Frontline Medical Communications Inc. 2014. All rights reserved.

References

1. Kurtz SM, Ong KL, Schmier J, Zhao K, Mowat F, Lau E. Primary and revision arthroplasty surgery caseloads in the United States from 1990 to 2004. *J Arthroplasty.* 2009;24(2):195-203.

2. Kurtz S, Ong K, Lau E, Mowat F, Halpern M. Projections of primary and revision hip and knee arthroplasty in the United States from 2005 to 2030. *J Bone Joint Surg Am.* 2007;89(4):780-785.
3. Pierson JL, Hannon TJ, Earles DR. A blood-conservation algorithm to reduce blood transfusions after total hip and knee arthroplasty. *J Bone Joint Surg Am.* 2004;86(7):1512-1518.
4. Spencer J, Thomas SR, Yardy G, Mukundan C, Barrington R. Are we overusing blood transfusing after elective joint replacement?—a simple method to reduce the use of a scarce resource. *Ann R Coll Surg Engl.* 2005;87(1):28-30.
5. Innerhofer P, Klingler A, Klimmer C, Fries D, Nussbaumer W. Risk for postoperative infection after transfusion of white blood cell-filtered allogeneic or autologous blood components in orthopedic patients undergoing primary arthroplasty. *Transfusion.* 2005;45(1):103-110.
6. Friedman RJ. Limit the bleeding, limit the pain in total hip and knee arthroplasty. *Orthopedics.* 2010;33(9 suppl):11-13.
7. Vekeman F, LaMori JC, Laliberté F, et al. Risks and cost burden of venous thromboembolism and bleeding for patients undergoing total hip or knee replacement in a managed-care population. *J Med Econ.* 2011;14(3):324-334.
8. Bozic KJ, Katz P, Cisternas M, Ono L, Ries MD, Showstack J. Hospital resource utilization for primary and revision total hip arthroplasty. *J Bone Joint Surg Am.* 2005;87(3):570-576.
9. Kagoma YK, Crowther MA, Douketis J, Bhandari M, Eikelboom J, Lim W. Use of antifibrinolytic therapy to reduce transfusion in patients undergoing orthopedic surgery: a systematic review of randomized trials. *Thromb Res.* 2009;123(5):687-696.
10. Ralley FE, Berta D, Binns V, Howard J, Naudie DD. One intraoperative dose of tranexamic acid for patients having primary hip or knee arthroplasty. *Clin Orthop.* 2010;468(7):1905-1911.
11. Sukeik M, Alshryda S, Haddad FS, Mason JM. Systematic review and meta-analysis of the use of tranexamic acid in total hip replacement. *J Bone Joint Surg Br.* 2011;93(1):39-46.
12. Alshryda S, Sarda P, Sukeik M, Nargol A, Blenkinsopp J, Mason JM. Tranexamic acid in total knee replacement: a systematic review and meta-analysis. *J Bone Joint Surg Br.* 2011;93(12):1577-1585.
13. Yang ZG, Chen WP, Wu LD. Effectiveness and safety of tranexamic acid in reducing blood loss in total knee arthroplasty: a meta-analysis. *J Bone Joint Surg Am.* 2012;94(13):1153-1159.
14. Ker K, Edwards P, Perel P, Shakur H, Roberts I. Effect of tranexamic acid on surgical bleeding: systematic review and cumulative meta-analysis. *BMJ.* 2012;344:e3054.
15. Hunink MGM, Glasziou PP, Siegel JE, et al. *Decision Making in Health and Medicine: Integrating Evidence and Values.* New York, NY: Cambridge University Press; 2001.
16. Blanchette CM, Wang PF, Joshi AV, Kruse P, Asmussen M, Saunders W. Resource utilization and costs of blood management services associated with knee and hip surgeries in US hospitals. *Adv Ther.* 2006;23(1):54-67.
17. Enquist M, Bosco JA 3rd, Pazand L, Habibi KA, Donoghue RJ, Zuckerman JD. Managing episodes of care: strategies for orthopaedic surgeons in the era of reform. *J Bone Joint Surg Am.* 2011;93(10):e55.
18. O'Brien JA, Caro JJ. Direct medical cost of managing deep vein thrombosis according to the occurrence of complications. *Pharmacoeconomics.* 2002;20(9):603-615.