



# Management of newly diagnosed hepatitis C virus infection

MARK W. RUSSO, MD, MPH; STEVEN L. ZACKS, MD, MPH; AND MICHAEL W. FRIED, MD

## ■ ABSTRACT

All patients with chronic hepatitis C virus infection are potential candidates for antiviral therapy. Careful patient selection can optimize the response to therapy and enhance safety. Pegylated forms of interferon, when combined with ribavirin, can "cure" the majority of patients undergoing therapy, and these agents have become the new standard of care for chronic hepatitis C. Careful and timely management of side effects, which are experienced by all patients, can improve adherence to antiviral therapy and further improve response rates.

The majority of patients infected with hepatitis C virus (HCV) can now be cured with a combination of the new pegylated forms of interferon plus ribavirin. These new regimens represent an important advance in the treatment of hepatitis C, but their safe and effective use in individual patients requires many careful clinical decisions. This article reviews these newest regimens for treating HCV infection, discusses how to determine a patient's eligibility for antiviral therapy for hepatitis C, and explores how to manage the adverse events commonly encountered during treatment.

## ■ WHO IS ELIGIBLE FOR HCV THERAPY?

Once the diagnosis of chronic HCV infection is established, the clinician must be ready to discuss treatment options with the patient and establish a plan for long-term management.

The recent National Institutes of Health consensus statement on hepatitis C noted that all patients with chronic hepatitis C are potential candidates for thera-

py.<sup>1</sup> In practice, however, many patients with chronic hepatitis C have significant comorbidities or other conditions that are contraindications to combination antiviral regimens for HCV infection, be they pegylated interferon alfa (peginterferon) plus ribavirin or standard interferon alfa plus ribavirin.<sup>2,3</sup> These exclusions to treatment are based on the well-established side effect profiles of these agents (discussed below), which may result in serious adverse events in high-risk patient groups.<sup>4</sup> Therefore, before initiating antiviral therapy for HCV infection, physicians must thoroughly examine the risks and benefits of therapy in the context of the individual patient's medical history.

## Absolute contraindications

Combination therapy with interferon (including peginterferons) plus ribavirin should never be initiated in the following patients:

- Female patients who (and male patients whose female partners) are pregnant, contemplating pregnancy, or unwilling to use adequate contraception (because of ribavirin's teratogenic effects)
- Patients with poorly controlled psychiatric disease, including recent history of suicide attempt (because of the psychiatric effects of interferons)
- Patients with symptomatic coronary artery disease (because of ribavirin-induced anemia).

## Potential contraindications, other cautions

Numerous other contraindications to therapy and cautions are noted in the package inserts of these antiviral agents. Among them:

- Autoimmune hepatitis or other well-documented autoimmune disease (because of exacerbation of immune-mediated diseases by interferons)
- Hepatic decompensation (Child-Pugh class B or C)
- Hemoglobinopathies (because of hemolysis from ribavirin)
- Breast-feeding
- Bipolar illness
- Renal insufficiency with creatinine clearance less

From the Division of Gastroenterology and Hepatology, University of North Carolina at Chapel Hill.

**Address:** Michael W. Fried, MD, University of North Carolina, CB# 7080, Room 1111 Bioinformatics, Chapel Hill, NC 27599.

than 50 mL/min (due to ribavirin's renal clearance)

- Preexisting neutropenia ( $< 1,500$  cells/mm<sup>3</sup>), a platelet count less than 90,000 cells/mm<sup>3</sup>, or hemoglobin less than 10 g/dL.

Some of these cautions may be considered relative, rather than absolute, contraindications to therapy, requiring treatment decisions to be individualized. An example would be a patient with well-compensated cirrhosis with hypersplenism. Although such a patient may not meet strict eligibility criteria because of cytopenias, this type of patient arguably has the most to gain from viral eradication, and a case can be made for the safe execution of treatment under careful monitoring. Similarly, the presence of an isolated antinuclear antibody or other autoantibody should not be considered a contraindication to therapy unless other clinical features of autoimmune hepatitis or systemic autoimmune diseases are apparent.<sup>5</sup>

### ■ HCV ERADICATION IS THE TREATMENT GOAL

The goal of therapy for hepatitis C is permanent eradication of HCV RNA from the serum. Sustained virologic response (SVR), defined as undetectability of HCV RNA in the serum by a sensitive nucleic acid assay 6 months after the completion of antiviral therapy, is synonymous with "cure" of HCV infection. It is well established that relapse beyond this 6-month post-treatment time point is unusual.<sup>6</sup> Furthermore, HCV RNA cannot be detected in liver tissue from patients who achieved SVR to antiviral therapy.<sup>7</sup>

Both of the new peginterferons (peginterferon alfa-2a [Pegasys] and peginterferon alfa-2b [PEG-Intron]) have demonstrated superiority in achieving SVR as monotherapy compared with standard interferon alfa,<sup>8-10</sup> and combination therapy with peginterferon and ribavirin has been established as the best available treatment for patients with chronic hepatitis C.<sup>1</sup>

### ■ PHARMACOKINETICS OF PEGINTERFERON

The peginterferons were developed by adding a polyethylene glycol (PEG) moiety to an interferon molecule, which alters the pharmacokinetic properties of the native protein, resulting in a prolonged serum half-life and the ability to administer the compound once weekly rather than three times weekly.

Peginterferon alfa-2a encompasses a branched, 40-kilodalton PEG moiety, whereas peginterferon alfa-2b encompasses a linear 12-kilodalton PEG moiety. Differences in the pharmacokinetic properties of peginterferons, such as serum half-life, are dependent on the size and configuration of the attached PEG

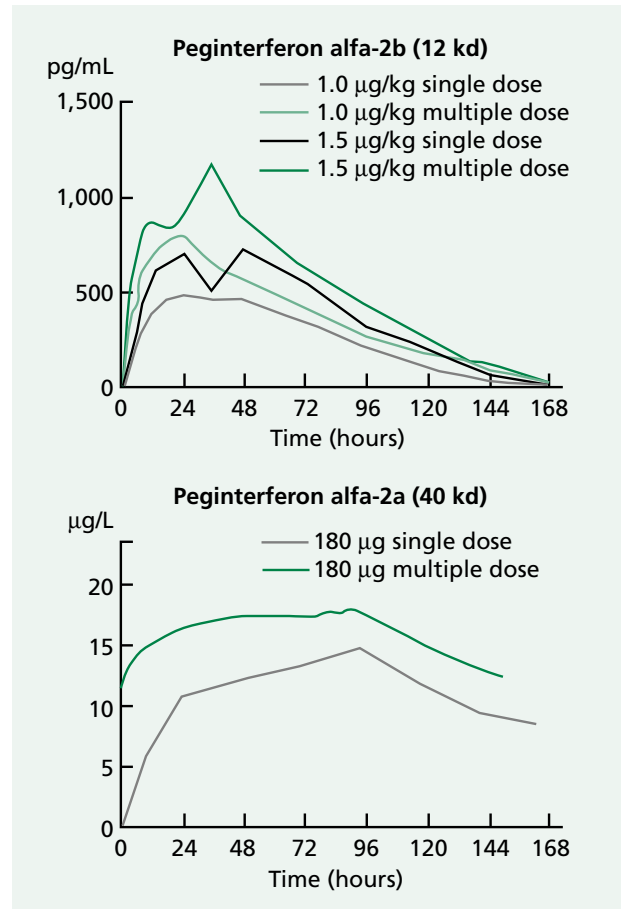

**FIGURE 1.** Mean serum concentration–time profiles of the peginterferons after administration of single and multiple doses (based on data from refs. 27 and 28). These agents' prolonged serum half-life allows once-weekly dosing.

moiety (Figure 1). In addition, the large PEG moiety of peginterferon alfa-2a strictly limits its volume of distribution so that a standard 180-µg dose is suitable for all patients. In contrast, peginterferon alfa-2b has a large volume of distribution, requiring that its dose be adjusted according to patient weight (1.5 µg/kg/week is recommended when used in combination with ribavirin). Like standard interferon, both peginterferons are given by subcutaneous injection.

### ■ CLINICAL TRIALS OF THE PEGINTERFERONS

#### Peginterferon alfa-2b and ribavirin

Manns et al<sup>11</sup> reported results from the first randomized trial of peginterferon alfa-2b combined with ribavirin. In this study, 1,530 patients with chronic hepatitis C were randomized to one of three combination regimens:

- Peginterferon alfa-2b 1.5 µg/kg/week plus riba-

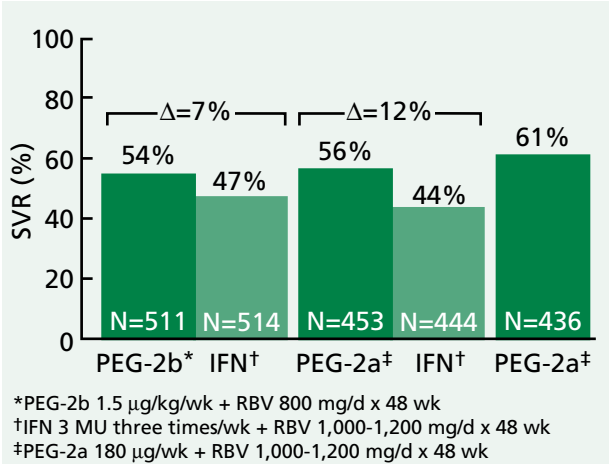

**FIGURE 2.** Sustained virologic response (SVR) rates from phase 3 studies of peginterferon alfa-2b (PEG-2b) and peginterferon alfa-2a (PEG-2a) compared with interferon alfa-2b (IFN). All regimens also included ribavirin (RBV). Results are by intention-to-treat analysis. Data for the two leftmost bars are from ref. 11, data for the two middle bars are from ref. 13, and data for the rightmost bar are from ref. 16, which had no IFN control arm.

virin 800 mg/day, both for 48 weeks

- Peginterferon alfa-2b 0.5 µg/kg/week for 44 weeks (after an initial 4 weeks of 1.5 µg/kg/week) plus ribavirin 1,000 to 1,200 mg/day for 48 weeks
- Interferon alfa-2b 3 MU three times weekly plus ribavirin 1,000 to 1,200 mg/day, both for 48 weeks.

At 24 weeks after the end of treatment, SVR was achieved in 54% of patients in the higher-dose peginterferon group compared with 47% of patients in each of the other treatment arms ( $P = .01$ ) (Figure 2).<sup>11</sup>

Among patients with HCV genotype 1 (a difficult-to-treat group; see below), SVR was achieved in 42% of those treated with the higher dose of peginterferon compared with 33% of those treated with standard interferon.<sup>11</sup> Among patients with the most treatment-resistant characteristics, genotype 1 and high levels of HCV viremia (> 2 million copies/mL), SVR was achieved in 30% of higher-dose peginterferon recipients and 29% of standard interferon recipients.<sup>12</sup> In contrast, patients with more favorable virologic characteristics (ie, HCV genotype 2 or 3) achieved SVR rates of approximately 80% across all treatment groups.

### Peginterferon alfa-2a and ribavirin

Fried and colleagues<sup>13</sup> reported results from the first phase 3 trial to evaluate the combination of peginterferon alfa-2a and ribavirin in previously untreated patients with chronic hepatitis C. Patients were treated for 48 weeks and followed for an additional

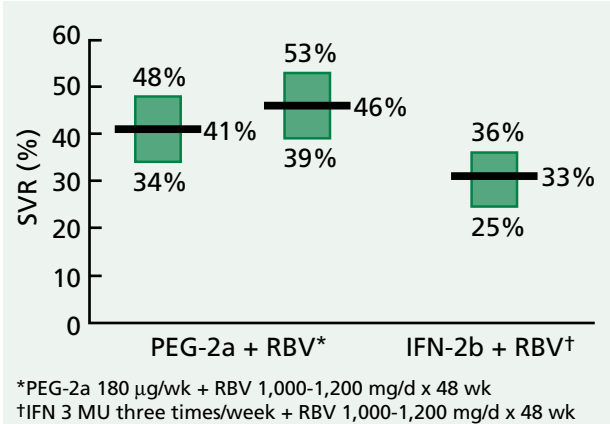

**FIGURE 3.** Sustained virologic response (SVR) rates in treatment-resistant patients (ie, with HCV genotype 1 and high levels of HCV RNA > 2 million copies/mL) in phase 3 studies of peginterferon alfa-2a plus ribavirin (RBV). Green bars represent 95% confidence intervals. The peginterferon data are from ref. 13 (left bar) and ref. 16 (middle bar). The right bar presents control SVR data for interferon alfa-2b plus ribavirin from ref. 13.

24 weeks to determine SVR rates. A total of 1,121 patients were randomly assigned to one of the following regimens:

- Peginterferon alfa-2a 180 µg/week plus ribavirin 1,000 to 1,200 mg/day
- Peginterferon alfa-2a 180 µg/week plus placebo
- Interferon alfa-2b 3 MU three times weekly plus ribavirin 1,000 to 1,200 mg/day.

The SVR rate was significantly higher in patients treated with peginterferon and ribavirin (56%) than in those receiving standard interferon and ribavirin (44%,  $P < .001$ ) or peginterferon and placebo (29%,  $P < .001$ ) (Figure 2). Among patients with HCV genotype 1, SVR was attained in 46% of those receiving peginterferon and ribavirin compared with 36% of those receiving standard interferon and ribavirin ( $P = .01$ ) Among patients with both genotype 1 and high levels of HCV viremia (> 2 million copies/mL), SVR was achieved in 41% of peginterferon/ribavirin recipients compared with 33% of standard interferon/ribavirin recipients (Figure 3).<sup>13</sup>

### GENOTYPE AND OTHER FACTORS AFFECT TREATMENT DURATION AND RIBAVIRIN DOSE

HCV genotype is the single factor that is most strongly predictive of treatment response to all approved antiviral agents.<sup>11,13-16</sup> Patients with genotype 1 have lower response rates than patients with genotypes 2 or 3. Given the variability in SVR rates to similar treatment regimens, it is conceivable that

**Treatment duration and ribavirin dose matter in patients with HCV genotype 1**

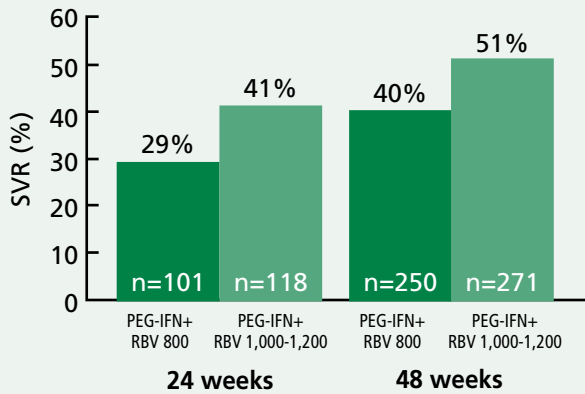

**FIGURE 4.** Rates of sustained virologic response (SVR) among patients with HCV genotype 1 in a phase 3 study of peginterferon alfa-2a (PEG-IFN) plus ribavirin (RBV).<sup>16</sup> Patients were treated for 24 or 48 weeks and received either a low (800 mg/day) or high (1,000–1,200 mg/day) dose of ribavirin. Higher SVR rates were associated with longer treatment and higher ribavirin dose.

a patient’s antiviral regimen could be tailored to his or her specific characteristics to increase the likelihood of response and minimize the costs and side effects of therapy.

The first prospective study to evaluate this possibility was a phase 3 trial<sup>16</sup> designed to assess the impact of treatment duration and ribavirin dose in patients receiving peginterferon alfa-2a and ribavirin. Patients were randomized to 24 or 48 weeks of treatment with peginterferon alfa-2a 180 µg/week and ribavirin at either 800 mg/day or 1,000 to 1,200 mg/day.

The overall SVR rate was 61% for patients treated for 48 weeks with peginterferon and the higher dose of ribavirin. Patients with HCV genotype 1 who received this regimen had an SVR rate of 51%. In contrast, patients with genotype 1 who received treatment for only 24 weeks (both the high-dose and low-dose ribavirin groups) had lower SVR rates (Figure 4). For patients with genotypes 2 or 3, however, the SVR rates were uniformly excellent (73% to 78%) regardless of therapy duration or ribavirin dose.<sup>16,17</sup> Among patients with the most treatment-resistant characteristics (genotype 1 and HCV RNA > 2 million copies/mL), the SVR rate with peginterferon and the higher dose of ribavirin was 46%,<sup>16</sup> similar to that seen in the previous study<sup>13</sup> (Figure 3).

These findings indicate that patients with treatment-resistant characteristics, such as HCV genotype 1, require prolonged therapy with higher doses

**Early virologic response strongly predicts sustained virologic response**

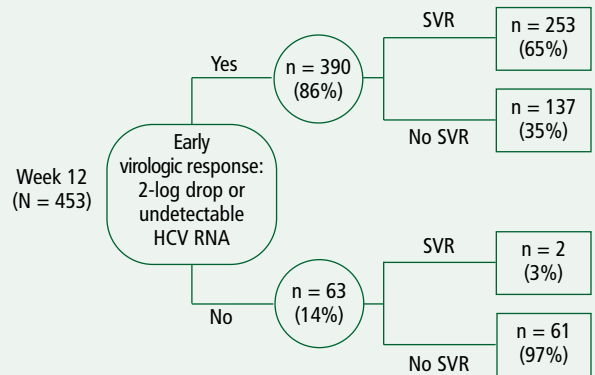

**FIGURE 5.** Schematic showing rates of sustained virologic response (SVR) in a phase 3 study of peginterferon alfa-2a plus ribavirin according to whether or not patients achieved early virologic response at treatment week 12. Reprinted from ref. 13 with permission. Copyright ©2002 Massachusetts Medical Society. All rights reserved.

of ribavirin to maximize their chance of achieving SVR. At the same time, patients with characteristics favorable to treatment response, such as HCV genotype 2 or 3, can achieve high rates of SVR with less aggressive regimens—namely, only 24 weeks of therapy with peginterferon alfa-2a and ribavirin and/or use of lower doses of ribavirin.<sup>17</sup> Of course, a regimen that reduces the duration of therapy and uses lower doses of ribavirin can decrease both the adverse events and the costs associated with antiviral therapy in patients with genotype 2 or 3.

**■ DYNAMIC PREDICTORS OF TREATMENT RESPONSE**

Although HCV genotype is the strongest pretreatment predictor of SVR, other factors—such as age less than 40 years, body weight less than 75 kg, and absence of cirrhosis—also have been associated with a favorable response to therapy,<sup>11,13</sup> although to much lesser degrees. It must be stressed that these pretreatment characteristics give *general* clues to the likelihood of response for a *population* of patients but provide little insight for the individual patient undergoing therapy. While knowledge of these variables is important for counseling patients prior to therapy, a factor that can predict response during treatment has more practical applications.

**Prognostic role of early virologic response**

Retrospective analyses of the large phase 3 trials of peginterferon alfa-2a and -2b plus ribavirin have

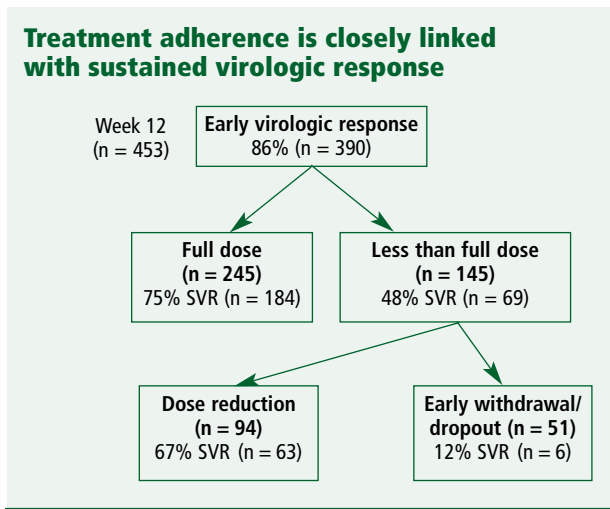

**FIGURE 6.** Schematic showing rates of sustained virologic response (SVR) in a phase 3 study<sup>13,20</sup> of peginterferon alfa-2a plus ribavirin according to adherence to the study's medication regimen. "Full dose" was defined as 80% or more of prescribed medication.

assessed the dynamic changes in virologic response during treatment.<sup>13,18</sup> In the study of peginterferon alfa-2a and ribavirin,<sup>13</sup> early virologic response (EVR), defined as undetectability of HCV RNA or at least a 2-log (100-fold) decrease in HCV RNA by week 12 of therapy, was shown to be useful in predicting the likelihood of subsequent SVR. As shown in **Figure 5**, 86% of patients treated with peginterferon alfa-2a and ribavirin had EVR. Of these patients, 65% subsequently achieved SVR. Perhaps more important, among the 14% of patients who did not attain EVR, virtually none (3%) subsequently achieved SVR (**Figure 5**).

The clinician can use this information in several ways. Patients achieving EVR can be encouraged to keep adhering to their medication regimens since their chances of ultimately achieving SVR are now increased above baseline. In contrast, if EVR is not achieved, the likelihood of subsequent SVR is so low that the clinician and patient can decide to discontinue treatment prematurely so as to not subject the patient to the continued adverse events and costs of therapy that will have no defined long-term benefits.

Several caveats are necessary, however. Because quantitative viral assays have inherent variability, significant antiviral effect can occur that is somewhat less than the 100-fold reduction cited above.<sup>19</sup> In these situations, treatment should be continued and HCV RNA measured again at 24 weeks to determine if viral eradication has occurred, at which point decisions about therapy continuation can be reevaluated. Additionally, the EVR analysis is also

influenced by HCV genotype. Because virtually all patients with genotype 2 or 3 achieve EVR (97%),<sup>20</sup> measurement of HCV RNA at week 12 in these patients probably does not influence management decisions in this group, whose standard course of therapy is only 24 weeks.

## ■ ADHERENCE IS KEY TO TREATMENT RESPONSE

Adherence to therapy is increasingly recognized as a key determinant in the outcome of antiviral therapy for chronic hepatitis C.<sup>20,21</sup> Patients who demonstrate EVR and are then able to maintain near-complete adherence to their regimen (> 80% of prescribed medications) have the highest likelihood of achieving SVR (75%) (**Figure 6**). In contrast, patients with lesser degrees of adherence have decreased rates of SVR (48%). Further analysis of the nonadherent group shows that dose modification has a relatively minor effect on the SVR rate (67%), whereas premature discontinuation almost assures treatment failure (12% SVR) (**Figure 6**).<sup>13,20</sup>

For these reasons, maintaining adherence to therapy must be a major goal for clinicians managing patients with chronic hepatitis C and the importance of adherence must be emphasized to all patients undergoing treatment.

## ■ SIDE EFFECTS AS BARRIERS TO ADHERENCE

The greatest barriers to adherence are medication side effects, which occur to some extent in all patients undergoing therapy for hepatitis C. These adverse events have a tremendous impact on patients' quality of life and contribute substantially to dose reductions or premature withdrawal during treatment.

In clinical trials, dose reductions (either temporary or permanent) for any adverse event were required in 32% to 42% of patients receiving peginterferon alfa-2a or -2b compared with 27% to 34% of patients receiving standard interferon.<sup>4,13,22</sup> Rates of premature therapy discontinuation due to adverse events were generally low with both peginterferon alfa-2a plus ribavirin (10%)<sup>13</sup> and peginterferon alfa-2b plus ribavirin (14%)<sup>11</sup> and were comparable to the rates with standard interferon plus ribavirin (11% and 13% in the respective studies).<sup>11,13</sup>

The side effects of peginterferons vary by preparation. Decreased rates of influenza-like symptoms and depression were noted in patients treated with peginterferon alfa-2a and ribavirin compared with those receiving standard interferon and ribavirin.<sup>13</sup>

These and other less common adverse events associated with peginterferon therapy have been reviewed previously.<sup>22</sup>

## ■ HOW TO MANAGE ADVERSE EVENTS

The management of side effects of medications for hepatitis C should begin even before the first dose is given. Treatment for hepatitis C never constitutes an emergency, so the timing of therapy initiation should be discussed before embarking on the treatment course. Knowledge about impending vacations, important business plans, or other upcoming momentous occasions can help determine when to start therapy in order to minimize the impact of side effects on quality of life and to encourage adherence. Patients should receive detailed instruction in the use of peginterferon and ribavirin and be given comprehensive information about what to expect during therapy.

Simple interventions can yield important improvements in patients' quality of life. Examples include administering peginterferon on Friday evenings in anticipation of less stress on weekends, maintaining adequate hydration, continuing a light to moderate exercise program, and judicious use of acetaminophen or nonsteroidal anti-inflammatory drugs to diminish the influenza-like symptoms and asthenia associated with therapy. Most important, patients receiving therapy must be seen by a health care professional in a supportive environment at regular, frequent intervals to allow for monitoring of adverse events, assessment of their severity, and quick intervention to prevent dose reduction or therapy disruption.

### Managing specific adverse events

The most frequent reasons for peginterferon dose reduction are neutropenia and depressive symptoms; the most common cause of ribavirin dose reduction is anemia.<sup>4</sup> Specific interventions for these adverse events may be useful in many patients.

**Neutropenia.** In clinical trials, the frequency of dose reduction for neutropenia was greater with both peginterferon agents compared with standard interferon (20% with peginterferon alfa-2a vs 5% with interferon,<sup>13</sup> and 18% with peginterferon alfa-2b vs 10% with interferon<sup>11</sup>). Approximately 4% to 5% of peginterferon recipients experienced grade 4 neutropenia (< 500 cells/mm<sup>3</sup>) in both studies. Neutropenia was not associated with an increased risk of infection.

Dose reduction, suggested for patients with neutrophil counts that fall below 750 cells/mm<sup>3</sup>, results

## Interferon-induced depression: Symptoms should guide antidepressant selection

### Depression and the spectrum of related symptoms

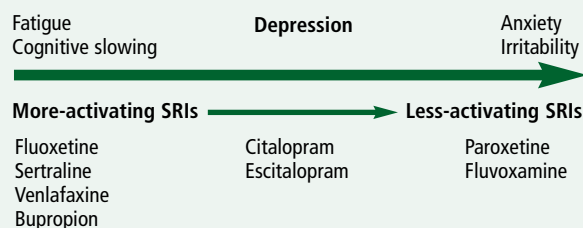

**FIGURE 7.** Selection of a serotonin reuptake inhibitor (SRI) for interferon-induced depression depends on the individual patient's symptoms. Patients with symptoms such as fatigue and cognitive slowing are candidates for one of the more-activating SRIs, whereas patients with symptoms indicative of higher degrees of activation, such as anxiety or irritability, are candidates for a less-activating SRI.

in a rapid increase of neutrophils within 1 to 2 weeks. Studies are under way to evaluate the safety of lowering the threshold for dose reduction to 500 cells/mm<sup>3</sup>. In cases of extreme neutropenia or when infection does occur, the use of granulocyte colony-stimulating factor raises neutrophil counts quickly.<sup>4,22,23</sup>

**Anemia.** Ribavirin universally induces an extravascular hemolysis due to depletion of erythrocyte ATP stores, leading to increased susceptibility to oxidative damage.<sup>24</sup> The average reduction in hemoglobin is approximately 2.5 to 3.0 g, although more significant decreases in hemoglobin and in symptoms associated with anemia are not uncommon, and they can substantially affect quality of life. Dose reduction, recommended for hemoglobin levels that fall below 10 g/dL in patients without any evidence of coronary artery disease, results in a rapid increase in hemoglobin levels.

An emphasis on adherence and maintaining ribavirin dosing has led to a search for alternate strategies to dose reduction. Epoetin alfa (40,000 units/week) was recently shown to maintain ribavirin dosing and to improve quality of life in patients who develop ribavirin-induced anemia.<sup>25</sup> Several questions remain, however, including the effects of epoetin alfa on SVR, its cost-effectiveness, and which subgroups of patients may benefit most from its use. At present, we reserve epoetin alfa for patients with markedly symptomatic anemia who require significant reductions in their ribavirin dose to maintain hemoglobin above 10 g/dL or in whom ribavirin discontinuation is immi-

ment because of severe anemia (between 8.5 and 10 g/dL). Initial management of these patients with severe anemia still requires transient ribavirin dose reduction and close monitoring until the hemoglobin values increase after administration of epoetin alfa (generally within 1 to 2 weeks).<sup>22</sup>

**Depression.** Approximately 20% to 30% of patients treated with peginterferon and ribavirin report depression during therapy.<sup>4,11,13</sup> This makes depression a frequent cause of decreased quality of life and an indication for dose reduction and discontinuation.<sup>22</sup> Specific questioning of the patient and his or her family or significant other about depressive symptoms should be undertaken at each follow-up visit during treatment.

Severe depression accompanied by suicidal ideation requires immediate discontinuation of antiviral therapy and immediate referral to mental health professionals. Lesser degrees of depression or other neuropsychiatric side effects can initially be managed with various antidepressant drugs, often in consultation with a local mental health care provider. There is growing consensus that serotonin reuptake inhibitors may be the drugs of choice for treating depression associated with interferon or peginterferon therapy in patients with chronic hepatitis C.<sup>22</sup> Because serotonin reuptake inhibitors may be more or less activating (stimulating), the choice of agent should be based on the patient's predominant symptoms<sup>26</sup> (Figure 7).

## REFERENCES

- National Institutes of Health Consensus Development Conference Statement: Management of hepatitis C 2002 (June 10–12, 2002). *Gastroenterology* 2002; 123:2082–2099.
- el-Serag HB, Kunik M, Richardson P, Rabeneck L. Psychiatric disorders among veterans with hepatitis C infection. *Gastroenterology* 2002; 123:476–482.
- Muir AJ, Provenzale D. A descriptive evaluation of eligibility for therapy among veterans with chronic hepatitis C virus infection. *J Clin Gastroenterol* 2002; 34:268–271.
- Fried MW. Side effects of therapy for hepatitis C and their management. *Hepatology* 2002; 36:S237–S244.
- Fried MW, Draguescu JO, Shindo M, et al. Clinical and serological differentiation of autoimmune and hepatitis C virus-related chronic hepatitis. *Dig Dis Sci* 1993; 38:631–636.
- Lau DT, Kleiner DE, Ghany MG, Park Y, Schmid P, Hoofnagle JH. 10-Year follow-up after interferon-alpha therapy for chronic hepatitis C. *Hepatology* 1998; 28:1121–1127.
- McHutchison JG, Poynard T, Esteban-Mur R, et al. Hepatic HCV RNA before and after treatment with interferon alone or combined with ribavirin. *Hepatology* 2002; 35:688–693.
- Zeuzem S, Feinman SV, Rasenack J, et al. Peginterferon alfa-2a in patients with chronic hepatitis C. *N Engl J Med* 2000; 343:1666–1672.
- Lindsay KL, Trepo C, Heintges T, et al. A randomized, double-blind trial comparing pegylated interferon alfa-2b to interferon alfa-2b as initial treatment for chronic hepatitis C. *Hepatology* 2001; 34:395–403.
- Heathcote EJ, Shiffman ML, Cooksley WG, et al. Peginterferon alfa-2a in patients with chronic hepatitis C and cirrhosis. *N Engl J Med* 2000; 343:1673–1680.
- Manns MP, McHutchison JG, Gordon SC, et al. Peginterferon alfa-2b plus ribavirin compared with interferon alfa-2b plus ribavirin for initial treatment of chronic hepatitis C: a randomised trial. *Lancet* 2001; 358:958–965.
- PEG-Intron [package insert]. Kenilworth, N.J.: Schering Corp; 2002.
- Fried MW, Shiffman ML, Reddy KR, et al. Combination of peginterferon alfa-2a plus ribavirin in patients with chronic hepatitis C virus infection. *N Engl J Med* 2002; 347:975–982.
- Fried MW. Clinical application of hepatitis C genotyping and quantitation. *Clin Liver Dis* 1997; 1:631–646.
- Pawlotsky JM. Hepatitis C virus genetic variability: pathogenic and clinical implications. *Clin Liver Dis* 2003; 7:45–66.
- Hadziyannis S, Cheinquer H, Morgan T, et al. Peginterferon alfa-2a in combination with ribavirin: efficacy and safety results from a phase III, randomized, double-blind, multicenter study examining effect of duration of treatment and ribavirin dose [abstract]. *J Hepatol* 2002; 36(suppl 1):3.
- Di Bisceglie AM, Hoofnagle JH. Optimal therapy of hepatitis C. *Hepatology* 2002; 36(suppl 1):S121–S127.
- Davis GL. Monitoring of viral levels during therapy of hepatitis C. *Hepatology* 2002; 36:S145–S151.
- Pawlotsky JM. Use and interpretation of virological tests for hepatitis C. *Hepatology* 2002; 36(suppl 1):S65–S73.
- Ferenci P, Shiffman ML, Fried MW, et al. Early prediction of response to 40KDA peginterferon alfa-2a (PEGASYS) plus ribavirin in patients with chronic hepatitis C [abstract]. *Hepatology* 2001; 34(suppl):351A.
- McHutchison JG, Manns M, Patel K, et al. Adherence to combination therapy enhances sustained response in genotype-1-infected patients with chronic hepatitis C. *Gastroenterology* 2002; 123:1061–1069.
- Russo MW, Fried MW. Side effects of therapy for chronic hepatitis C. *Gastroenterology* 2003; 124:1711–1719.
- Van Thiel DH, Faruki H, Friedlander L, et al. Combination treatment of advanced HCV associated liver disease with interferon and G-CSF. *Hepatogastroenterology* 1995; 42:907–912.
- De Franceschi L, Fattovich G, Turrini F, et al. Hemolytic anemia induced by ribavirin therapy in patients with chronic hepatitis C virus infection: role of membrane oxidative damage. *Hepatology* 2000; 31:997–1004.
- Afdhal NH, Dieterich DT, Pockros PJ, et al. Epoetin alfa treatment of anemic HCV-infected patients allows for maintenance of ribavirin dose, increases hemoglobin levels, and improves quality of life vs placebo: a randomized, double-blind multicenter study [abstract]. *Gastroenterology* 2003; 124(suppl):505.
- Edwards JG, Anderson I. Systematic review and guide to selection of selective serotonin reuptake inhibitors. *Drugs* 1999; 57:507–533.
- Glue P, Rouzier-Panis R, Raffanel C, et al. A dose-ranging study of pegylated interferon alfa-2b and ribavirin in chronic hepatitis C. *Hepatology* 2000; 32:647–653.
- Algranati NE, Sy S, Modi M. A branched methoxy 40 kDa polyethylene glycol moiety optimizes the pharmacokinetics of peginterferon alfa-2a and may explain its enhanced efficacy in chronic hepatitis C. *Hepatology* 1999; 30(4 Pt 2):190A. Abstract 120.