

## New strategies in nonantibiotic treatment of gram-negative sepsis

JUDITH COHN, MD, PhD, AND ROGER C. BONE, MD

■ Gram-negative bacterial infections are difficult to control and often lead to septic shock or septic syndrome. Many physiologic changes in sepsis are due to bacterial triggering of host responses. Improved understanding of these mechanisms has led to new treatment modalities that aim to block the runaway inflammatory process of sepsis. New therapeutic agents are currently being evaluated in animal and human studies. By combining these advances with adequate antibiotic therapy, it may be possible to improve overall survival in patients with gram-negative sepsis.

□ INDEX TERMS: GRAM-NEGATIVE BACTERIA; BACTERIAL INFECTIONS; ANTI-INFLAMMATORY AGENTS □ CLEVE CLIN J MED 1992; 59:608-615

**B**ROAD-SPECTRUM ANTIBIOTIC treatment of infections has improved considerably in the last 20 years. Physicians are more aware of the early warning signs of infection and are better equipped to diagnose them. A more extensive arsenal of therapies is available to prevent infection from progressing to septic shock and death. However, even though gram-positive infections can be readily controlled, gram-negative bacteria remain a difficult problem, particularly when nosocomial in nature.<sup>1</sup>

Although antibiotics are important in treating gram-negative infections, they have limited efficacy when the infection is severe.<sup>2,3</sup> In the 5-year period from 1977 to 1981, mortality in 1,186 episodes of gram-negative bacteremia was 36.3%, a rate com-

parable to that in 1924—before the advent of sulfonamides and antibiotics. Mortality rates are especially high in nosocomial lung infections: up to 70% in patients with *Pseudomonas* pneumonia and 33% in patients with pneumonia due to other gram-negative bacteria. Pneumonia caused by gram-positive species has a mortality of only 5%.<sup>4,5</sup>

The incidence of gram-negative sepsis in the United States is estimated to range from 300,000 to 800,000 cases per year, with associated mortality rates up to 75%. When shock occurs in association with sepsis, the mortality rate increases to 85% to 90%.<sup>6</sup> The need for additional therapeutic agents for sepsis is clear.

Recent innovations in medical practice and their consequences may have increased the likelihood of sepsis and septic shock<sup>7</sup>; these include aggressive oncologic chemotherapy, corticosteroid or immunosuppressive therapy for organ transplantation or inflammatory diseases, increased survival of patients predisposed to sepsis, and more frequent use of invasive medical procedures.<sup>7,8</sup> In addition, the escalating number of patients with AIDS contributes to the rising incidence of sepsis.

From the Department of Internal Medicine, Section of Pulmonary and Critical Care, Rush-Presbyterian-St. Luke's Medical Center, Chicago.

Address reprint requests to J.C., Immunoscience Venture, Pharmaceutical Products Division, Department 048K, Building AP6A-1, Abbott Laboratories, One Abbott Park Road, Abbott Park, IL 60064-3500.

Many of the physiologic changes in sepsis that lead to irreversible tissue injury and death are due to bacterial triggering of host responses.<sup>9</sup> Specifically, deleterious consequences of sepsis are related, at least in part, to host production of proinflammatory cytokines, which initiates a cascade of events that may eventually lead to irreversible tissue injury and lethal hypotension (Figure 1). Approaches designed to intervene in this chain of events include nonspecific suppression of host responses with glucocorticoids.<sup>10,11</sup> While animal studies using glucocorticoids have shown promise in the treatment of sepsis, two large randomized clinical trials have failed to show efficacy.

#### NEW TREATMENT MODALITIES

Improved understanding of disease mechanisms is fueling much research on sepsis syndrome and multiple organ failure. A number of new treatment modalities for sepsis are being evaluated in animal and human studies (Table). A brief summary of their applications follows.

#### Opioid antagonists

Naloxone, an opioid antagonist, has emerged as an alternative therapeutic agent for severe sepsis. Although not yet approved in this context, naloxone is effective in reversing endotoxin-mediated hypotension by blocking  $\beta$ -endorphins.<sup>12,13</sup> In a canine model of endotoxic shock, cardiac output increases after opioid antagonism; however, the physiologic mechanism for this effect has not yet been established.<sup>14,15</sup> Human studies with naloxone have demonstrated increased mean arterial pressure and improved hemodynamic profile in a subgroup of patients with severe early hyperdynamic septic shock, but evidence of naloxone's influence on survival is equivocal.<sup>16-18</sup> In the late stages of septic shock, naloxone has little effect; factors contributing to this decreased effectiveness include acidemia and hypothermia. Furthermore, the pressor effect of naloxone is seriously blunted by concomitant steroid administration.

#### Nonsteroidal anti-inflammatory drugs

Several other agents have been used in attempts to block the inflammatory reaction and the production of inflammatory mediators. In animal models of gram-negative sepsis, ibuprofen improves hemodynamics, reverses lactic acidosis, and increases survival.<sup>19,20</sup> In the dog, indomethacin and aspirin appear to improve

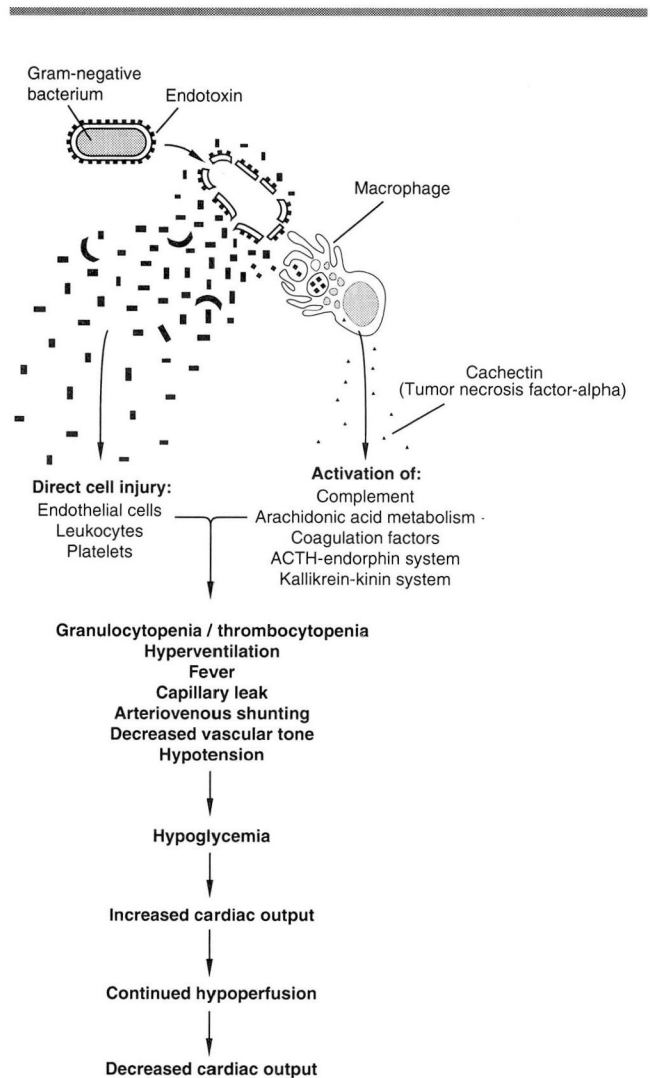

FIGURE 1. Diagram of bacterial triggering of host responses, a cascade of events that may lead to tissue injury and lethal hypotension. From Mostow SR. Management of gram-negative septic shock. Hospital Practice (October 15, 1990: 121-130), with permission.

the outcome of sepsis<sup>21</sup> (perhaps through their ability to block cyclooxygenase), improve neutrophil bactericidal activity, and improve cell-mediated immunity. In cats, most of the pulmonary effects of endotoxin are completely abolished when inhibitors of cyclooxygenase (eg, indomethacin, meclufenamate, flurbiprofen) are administered in doses that prevent the generation of prostaglandin  $F_{2\alpha}$  and thromboxane  $A_2$ .<sup>22</sup> Prophylactic or therapeutic administration of

**TABLE**  
EXPERIMENTAL NON-ANTIBIOTIC THERAPIES  
FOR GRAM-NEGATIVE SEPSIS

---

Opioid antagonists
Nonsteroidal anti-inflammatory drugs
Prostaglandin E <sub>1</sub>
Pentoxifylline
Surfactant replacement
Antioxidants
Antibodies to endotoxin
Monoclonal antibodies to tumor necrosis factor
Interleukin-1 receptor antagonists
Platelet activating factor antagonists
Leukotriene inhibitors

---

ibuprofen, even at high doses, does not modulate the increase in pulmonary microvascular permeability (which may be amplified by cyclooxygenase products at early stages) that follows endotoxin administration.<sup>23</sup> In a preliminary report on the use of rectally administered ibuprofen in 30 septic syndrome patients, there were improvements in blood pressure, heart rate, and minute ventilation, but no effect on gas exchange.<sup>24</sup> Clinical trials continue, and any potential role for ibuprofen or nonsteroidal anti-inflammatory drugs in sepsis syndrome has yet to be defined.

### Prostaglandin E<sub>1</sub>

Bacteremia is commonly associated with the development of adult respiratory distress syndrome (ARDS). Prostaglandin E<sub>1</sub> includes among its actions the ability to inhibit leukocyte aggregation and the release of lysosomal enzymes and free radical oxygen species, and to reduce lung vascular permeability. In some clinical trials in the management of ARDS, prostaglandin E<sub>1</sub> improves perfusion abnormalities and survival.<sup>25,26</sup> However, in a recent multicenter trial of ARDS patients, this agent did not improve outcome.<sup>26</sup> The toxicity associated with the use of prostaglandin E<sub>1</sub> was significant and included fever, diarrhea, hypotension, and supraventricular arrhythmias.

### Pentoxifylline

Pentoxifylline is another agent that holds promise for the treatment of sepsis and ARDS. Pentoxifylline has diverse anti-inflammatory properties that reduce lung edema and protein leak. It increases survival in experimental animals with acute lung injury and septic shock.<sup>27-29</sup> Pentoxifylline also depresses neutrophil function in an inflammatory state but not in the "resting state." It decreases neutrophil superoxide production, granulation, and adherence to endothelial cells

and other cell surfaces, and it increases neutrophil chemotaxis. In addition, pentoxifylline decreases tumor necrosis factor (TNF) production by macrophages.<sup>30</sup> Since pentoxifylline is effective in animal models of sepsis, a clinical trial in septic patients seems warranted.

### Surfactant replacement

A large multicenter clinical trial is evaluating whether surfactant replacement has a role in treating ARDS. Injured lungs in sepsis show diffuse interstitial and alveolar edema. Loss of surfactant function would be expected to promote alveolar collapse, leading to loss of lung volume, shunt, and hypoxemia—major features of the pathophysiology of ARDS. At least one study has shown that lung surfactant function and chemical composition are altered in ARDS.<sup>31</sup> In addition, diminished surface tension within alveoli may protect against the development of alveolar edema, and loss of surfactant function might promote alveolar edema.<sup>32,33</sup> In phase II clinical trials of 2,000 infants given a synthetic lung surfactant to treat respiratory distress, the overall mortality rate was reduced from 51% to 31%.<sup>34</sup> However, another large multicenter randomized trial demonstrated no difference in survival in spite of rapid improvement in oxygenation and ventilation and a lower incidence of pneumothorax.<sup>35</sup> Health and human services officials believe artificial surfactants are responsible for an 8% drop in infant mortality rate in the United States between 1989 and 1991. Randomized placebo-controlled dose ranging studies involving 100 adult patients with sepsis-induced-ARDS demonstrated that the gas exchange function of the lungs consistently improved in the surfactant treated groups. Moreover, the mortality rate of the placebo group was 50%, and the most effective dose of surfactant had a 25% mortality rate.<sup>36</sup>

### Antioxidants

Another approach to treating inflammatory lung injury is to block specific substances thought to mediate tissue damage. Antioxidant therapy with N-acetylcysteine or with liposome-encapsulated antioxidant catalase and superoxide dismutase ameliorates experimental lung injury due to sepsis.<sup>37,38</sup> A clinical trial of N-acetylcysteine in human subjects is currently underway. One uncontrolled study showed beneficial effects of tocopherol (vitamin E), but this remains to be confirmed.<sup>39</sup>

In a rat model of endotoxemia, the hydroxyl ion scavenger dimethylthiourea appeared to prevent in-

creases in extravascular lung water after perfusion with activated polymorphonuclear leukocytes.<sup>40</sup> In cannulated pigs, dimethylthiourea markedly attenuates alterations in cardiovascular and pulmonary membrane permeability caused by endotoxemia.<sup>41</sup> However, in a sheep model this compound had no effect on the early cardiovascular responses.<sup>42</sup> Furthermore, a major disadvantage of dimethylthiourea compared with enzymatic antioxidants is its limited capacity to scavenge oxygen metabolites.

Metal chelating agents may be effective antioxidants because they bind transition metals such as iron, thereby inactivating their catalytic participation in the generation of hydroxyl ions. Iron chelation therapy has not been investigated in acute lung disorders largely because of the toxicity of available agents. A new generation of iron chelating agents, with intestinal absorption adequate for oral administration and preferential reactions with parenchymal iron deposits, may be more suitable for human studies.<sup>43,44</sup>

### Antibodies to endotoxin

Much of the morbidity associated with gram-negative infections, including vascular collapse and death, is caused by lipid A (Figure 2), the biologically active component of bacterial lipopolysaccharide. Antibiotics cannot prevent the toxic effects of lipid A, and they may even promote its release from bacteria.<sup>45</sup> The clinical significance of this is that when antibiotics kill gram-negative organisms, endotoxin may remain active for an additional 12 hours—more than enough time in which to exert its detrimental systemic effects.

A promising new approach to treating gram-negative infections is passive immunotherapy with antibodies directed against cross-reactive core determinants on lipopolysaccharide.<sup>46,47</sup> As with all the agents described thus far, this approach employs the basic tactic of interfering with injury by one of the following mechanisms: (1) reducing neutrophil chemoattraction and aggregation in the pulmonary capillary bed; (2) modulating neutrophil behavior to prevent release of free radical oxygen species, proteases, and arachidonic acid metabolites; or (3) decreasing the quantity of toxic substances released by neutrophils or other cells, tissues, or organisms.

A 1982 study of patients with sepsis who were treated with a combination of antibiotics and human antisera directed against the J5 antigen of endotoxin demonstrated that mortality caused by gram-negative sepsis with shock decreased from 77% to 44%.<sup>48</sup> Other investigators subsequently found that postoperative ad-

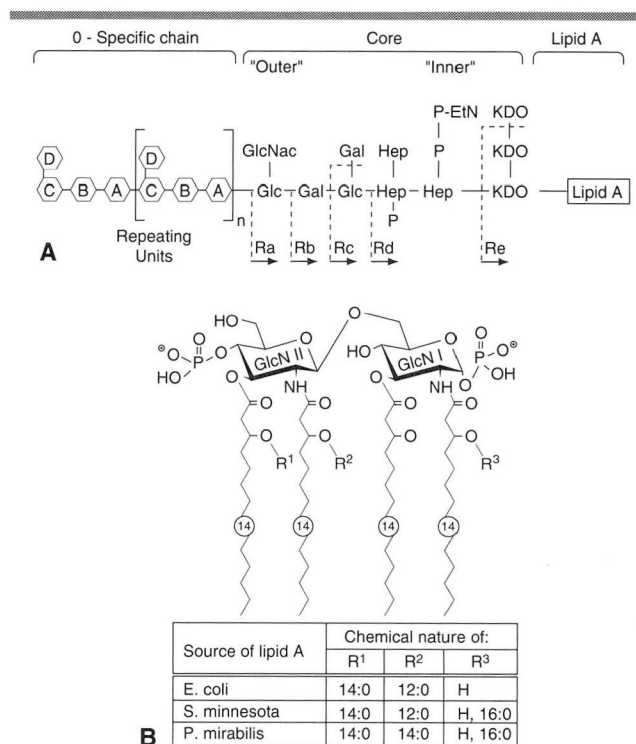

FIGURE 2. A. Structure of the outer membranes (lipopolysaccharides) of enteric bacteria. The “O” antigen side chains of repeating monosaccharide units are linked to lipid A through a “core” structure consisting of N-acetylglucosamine (GlcNac), glucose (Glu), galactose (Gal), heptose (Hep), phosphate (P), ethanolamine (EtN), and 2-keto, 3-deoxyoctonate (KDO). Chemotype mutants of increasing “roughness,” such as “Ra” and “Rc,” result from the progressive deletion of sugars from the outer to the inner core. The *E. coli* core region contains two KDOs. B. The chemical structure of the lipid A component of *E. coli*, *S. minnesota*, and *P. mirabilis* contains two N-acetylglucosamine residues (GlcN). The numbers in circles indicate the number of carbon atoms in the acyl chains. The distribution of normal fatty acids is highly specific and characteristic for the bacterial genus. From Mandell GL, Douglas RG, Bennett JE. Principles and practice of infectious diseases. New York: Churchill Livingstone Inc, 1990:618, with permission.

ministration of anti-J5 antiserum given prophylactically could effectively reduce the incidence of septic shock in surgical patients. In one study where immunoglobulin G antiserum was used, there was a dramatic reduction in peripartum septic shock from 47% to 7%, accompanied by rapid increase in blood pressure and reduction in hospital stay.<sup>49</sup> However, the difficulty in obtaining large supplies of antibody and the risks associated with the administration of pooled human plasma have prevented this agent from being used extensively.

Monoclonal antibody techniques circumvent this problem and allow large quantities of human monoclonal immunoglobulin M (IgM) antibody to be produced. Human monoclonal IgM antibody (HA-1A) binds to the lipid A domain of endotoxin.<sup>50</sup> In a multicenter trial involving more than 500 patients, HA-1A reduced mortality and organ failure in patients with gram-negative bacteremia (with or without shock).<sup>51</sup> E5, a murine-derived but "humanized" IgM monoclonal antibody to the J5 mutant, was effective in a randomized, placebo-controlled, multicenter trial.<sup>52</sup> Treatment with E5 reduced mortality and more effectively prevented multiorgan failure in all patients with gram-negative infection without refractory shock, compared with patients given placebo. A second E5 study examined patients with gram-negative sepsis and evidence of organ failure but not in refractory shock. This treatment did not affect overall survival but did affect the resolution and development of organ failure.<sup>53</sup> Both monoclonal antibodies were well tolerated and safe, yet in both studies sizeable subgroups of patients did not benefit from therapy. This suggests that a broader spectrum of immunotherapy for patients with sepsis would be desirable.

### Monoclonal antibodies to TNF

Several lines of evidence clearly link TNF-alpha to physiologic events that occur during sepsis and septic shock. When injected into animals, TNF-alpha leads to hemodynamic collapse, multiple organ injury, and a life-threatening vascular leak syndrome.<sup>9,54,55</sup> Several studies have shown that antibodies to TNF-alpha, even when given after septic shock has begun, may protect animals against lethal doses of endotoxin.<sup>56-58</sup> Similar trials are currently being conducted in humans with sepsis syndrome and ARDS. More than 35 patients in phase I clinical studies have received TNF-alpha murine monoclonal antibody. In one of these studies, 14 patients with severe septic shock responded to this therapy by a marked increase in mean arterial pressure; no adverse effects were noted,<sup>59</sup> and overall survival was not affected. Thus far in the multicenter phase II trials with the murine monoclonal antibody to TNF there has been no effect on mortality.<sup>59</sup>

### Interleukin-1 receptor antagonists

Interleukin-1 serum levels increase in animals and humans who have received endotoxin or who have septic shock.<sup>60,61</sup> An interleukin-1 receptor antagonist that has been cloned and expressed inhibits some of the biologic activities of interleukin-1 in animals.

More importantly, it appears to prevent endotoxin- and *Escherichia coli*-induced shock in rabbits and mice.<sup>62,63</sup> In a recent, small, prospectively randomized trial, the interleukin-1 receptor antagonist reduced mortality in patients with sepsis syndrome from 44% to 16%. These phase II trials also showed a clear dose-response curve, with the highest dose tested achieving a 64% reduction in mortality versus placebo.<sup>64</sup> Phase III clinical trials in patients with this agent are currently underway and are due to be completed this year.

### Platelet activating factor antagonists

Platelet activating factor, a potent phospholipid generated after phospholipase activation, has a variety of actions that are relevant to the pathogenesis of shock, including thromboxane- and adenosine diphosphate-independent platelet and neutrophil aggregation (leading to thrombocytopenia and neutropenia), chemotaxis, systemic hypotension, myocardial depression (bradycardia, reduced cardiac output), and pulmonary changes (eg, increased airway resistance and reduced lung compliance).<sup>65,66</sup> In certain experimental models, pretreating animals with relatively specific platelet activating factor receptor antagonists prevents some endotoxin-induced changes and improves survival.<sup>67-71</sup> Until platelet activating factor antagonists are shown to have beneficial effects in humans, the potential applications for these drugs are speculative.

### Leukotriene inhibitors

As with platelet activating factor, most of the evidence suggesting a role for leukotrienes in the vascular changes of sepsis comes from infusion studies, although a few studies have directly measured lipoxygenase products in septic animals.<sup>72-78</sup> Also, in animal studies, there are reports that 5-lipoxygenase inhibitors and leukotriene receptor antagonists have beneficial effects in endotoxemia.<sup>78-82</sup> Because this class of inhibitors has shown safety and efficacy in clinical trials for other inflammatory indications, it is likely that clinical trials will soon begin for gram-negative sepsis.

---

### CONCLUSION

---

Aside from the therapies described in this article, newer approaches are still in early stages of animal experimentation. These include nitric oxide synthesis inhibitors, lipid A-like molecules that antagonize LPS, and monoclonal antibodies to polymorphonuclear

leukocyte CD11/CD18 adhesion molecules.<sup>83-90</sup> It is too early to know whether these will have any clinical application.

New treatment modalities for gram-negative sepsis have developed from an improved understanding of disease mechanisms. The agents described above rep-

resent approaches to therapy that aim to block the runaway inflammatory process of sepsis. These agents are now being evaluated in animal and clinical trials. By combining these advances with adequate antibiotic therapy, it should be possible to improve overall survival in patients with gram-negative sepsis.

#### REFERENCES

- Rogers DE. The changing pattern of life-threatening microbial disease. *N Engl J Med* 1959; **261**:677-683.
- Bryan CS, Reynolds KL, Brenner ER. Analysis of 1,186 episodes of gram-negative bacteremia in non-university hospitals; the effect of antimicrobial therapy. *Rev Infect Dis* 1983; **5**:629-638.
- McGowan JE, Barnes MW, Finland M. Bacteremia at Boston City Hospital: occurrence and mortality during 12 selected years (1935-72), with special reference to hospital-acquired cases. *J Infect Dis* 1975; **132**:316-335.
- Tobin MK, Grenvik A. Nosocomial lung infection and its diagnosis. *Crit Care Med* 1984; **12**:191-199.
- Sanders CC, Sanders WE Jr. Microbial resistance to newer generation B-lactam antibiotics: clinical and laboratory implications. *J Infect Dis* 1985; **151**:399-406.
- Sinanian M, Maier RV, Corrico J. Laparotomy for inter-abdominal sepsis in an intensive care unit. *Arch Surg* 1985; **119**:652-658.
- Parker MM, Parrillo JE. Septic shock: hemodynamics and pathogenesis. *JAMA* 1983; **250**:3324-3327.
- Shubin H, Neil MH. Bacterial shock. *JAMA* 1976; **235**:421-424.
- Tracey KJ, Beutler B, Lowry SF, et al. Shock and tissue injury induced by recombinant human cachectin. *Science* 1986; **234**:470-474.
- Bone RC, Fisher CJ, Clemmer T, Slotman GJ, Metz CA, Balk RA. A controlled clinical trial of high-dose methylprednisolone in the treatment of severe sepsis and septic shock. *N Engl J Med* 1987; **317**:653-658.
- Hinshaw L, Peduzzi P, Young E, et al. Effect of high dose glucocorticoid therapy on mortality in patients with clinical signs of systemic sepsis. *N Engl J Med* 1987; **317**:659-665.
- Peters WP, Friedman PA, Johnson MW, Mitch WE. Pressor effect of naloxone in septic shock. *Lancet* 1981; **I**:529-532.
- Holaday JW, Faden AL. Naloxone reversal of endotoxin hypotension suggests role of endorphins in shock. *Nature* 1978; **275**:450-451.
- Reynolds DG, Gurril NJ, Vargish T, et al. Blockade of opiate receptors with naloxone improves survival and cardiac performance in canine endotoxin shock. *Circ Shock* 1980; **7**:39-48.
- Murray MJ, Offord KP, Yaksh TC. Physiologic and plasma hormone correlates of survival in endotoxic dogs. Effects of opiate antagonists. *Crit Care Med* 1989; **17**:39-47.
- Hackshaw KV, Parker GA, Roberts JW. Naloxone in septic shock. *Crit Care Med* 1990; **18**:47-51.
- Safani M, Blair J, Ross D, Waki R, Li C, Libby G. Prospective controlled, randomized trial of naloxone infusion in early hyperdynamic septic shock. *Crit Care Med* 1989; **17**:1004-1009.
- Roberts DW, Hall KW, Dobson KE, et al. Effects of prolonged naloxone infusion in septic shock. *Lancet* 1988; **II**:699-702.
- Jacobs ER, Soulsby ME, Bone RC, Wilson FJ, Hiller FC. Ibuprofen in canine endotoxin shock. *J Clin Invest* 1982; **70**:530-541.
- Jacobs ER, Bone RC, Balk R, Wilson FJ. Increased survival in bacteremic sheep treated with ibuprofen. *Crit Care Med* 1986; **3**:142-149.
- Fletcher JR, Ramwell PW. Modification by aspirin and indomethacin of the hemodynamic and prostaglandin releasing effects of *E. coli* in the dog. *Br J Pharmacol* 1977; **61**:175-181.
- Parratt JR, Pacitti N, Rodger IW. Mediators of acute lung injury in endotoxemia. *Prog Clin Biol Res* 1989; **308**:357-369.
- Jesmok GJ, Aono F, Simpson J, Borgia J. Effect of ibuprofen on components of an acute systemic inflammatory response evoked by intravenous endotoxin administration in conscious sheep. *Prog Clin Biol Res* 1987; **236A**:333-346.
- Bernard GR, Reines HD, Halushka PV, et al. Prostacyclin and thromboxane A<sub>2</sub> formation is increased in human sepsis syndrome. *Am Rev Respir Dis* 1991; **144**:1095-1101.
- Holcroft JW, Vassar MJ, Weber CJ. Prostaglandin E<sub>1</sub> and survival in patients with the adult respiratory distress syndrome. *Ann Surg* 1986; **203**:371-378.
- Bone RC, Slotman G, Maunder RJ, et al. Randomized double-blind multicenter study of prostaglandin E<sub>1</sub> in patients with the adult respiratory distress syndrome. *Chest* 1986; **96**:114-119.
- Mandell GL. ARDS, neutrophils, and pentoxifylline. *Am Rev Respir Dis* 1988; **138**:1103-1105.
- Puranapanda V, Hinshaw LB, O'Rear EA, Chang AC, Whitsett TL. Erythrocyte deformability in canine septic shock and the efficacy of pentoxifylline and a leukotriene antagonist. *Proc Soc Exp Biol Med* 1987; **185**:206-210.
- Hoffman H, Hatherill JR, Crowley J, et al. Early post-treatment with pentoxifylline or dibutyryl CAMP attenuates *Escherichia coli*-induced acute lung injury in guinea pigs. *Am Rev Respir Dis* 1991; **143**:289-293.
- Strieter RM, Remick DG, Ward PA. Cellular and molecular regulation of tumor necrosis factor-alpha production by pentoxifylline. *Biochem Biophys Res Commun* 1988; **155**:1230-1236.
- Hallmar M, Spragg RG, Harrell JH, Moser KM, Gluck L. Evidence of lung surfactant abnormality in respiratory failure. Study of bronchovascular lavage phospholipids, surface activity, phospholipase activity, and plasma myoinositol. *J Clin Invest* 1982; **70**:673-683.
- Bredenberg CE, Nieman GF, Paskanik AM, Hart KE. Microvascular membrane permeability in high surface tension pulmonary edema. *J Appl Physiol* 1986; **60**:253-259.
- Nieman GF, Bredenberg CE. High surface tension pulmonary edema induced by detergent aerosol. *J Appl Physiol* 1985; **58**:129-136.
- Collaborative European Multicenter Study Group. Surfactant replacement therapy for severe neonatal respiratory distress syndrome: an international randomized clinical trial. *Pediatrics* 1988; **82**:683-691.
- Horbar JD, Soll RF, Sutherland JM, et al. A multicenter randomized, placebo controlled trial of surfactant therapy for respiratory distress syndrome. *N Engl J Med* 1989; **320**:959-965.
- Wiedemann H, Baughman R, deBoisblanc B, et al. A multicenter trial in human sepsis-induced ARDS of an aerosolized synthetic surfactant (exosurf). *Am Rev Respir Dis* 1992; **145**(part 2):A184.
- Bernard GR, Lucht WD, Niedermeyer ME, Snapper JR, Ogletree ML, Bigham KL. Effect of N-acetylcysteine on the pulmonary response to endotoxin in the awake sheep and upon *in vitro* granulocyte function. *J Clin Invest* 1984; **73**:1772-1784.
- Turrens J, Crapo J, Freeman B. Protection against oxygen toxicity by intravenous injection of liposome-entrapped catalase and superoxide dismutase. *J Clin Invest* 1984; **73**:87-95.
- Wolf HRD, Seeger HW. Experimental and clinical results in shock lung treatment with vitamin E. *Ann N Y Acad Sci* 1982; **393**:392-409.
- Fox R. Prevention of granulocyte-mediated oxidinjury in rats by a hydroxyl radical scavenger, dimethylthiourea. *J Clin Invest* 1984; **74**:1456-1464.
- Olson NC, Anderson DL, Guzzle MK. Dimethylthiourea attenuates endotoxin-induced acute respiratory failure in pigs. *J Appl Physiol* 1987; **63**:2426-2432.

42. Wong C, Fox R, Demling RH. Effect of hydroxyl radical scavenging on endotoxin-induced lung injury. *Surgery* 1985; **97**:300-306.
43. Halliwell B, Gutteridge JMC. Oxygen free radicals and iron in relation to biology and medicine. Some problems and concepts. *Arch Biochem Biophys* 1986; **246**:501-514.
44. Hershko C. Oral iron chelating drugs: coming but not yet ready for clinical use. *Br Med J* 1988; **296**:1081-1082.
45. Shenep JL, Morgan KA. Kinetics of endotoxin release during antibiotic therapy for experimental gram-negative bacterial sepsis. *J Infect Dis* 1984; **150**:330-388.
46. Telzak E, Wolff SM. Immunotherapy and immunoprophylaxis of gram-negative rod bacteremia. In: Proctor PK, Sande ME, eds. *Septic shock*. New York: Churchill Livingstone, 1985: 257-276.
47. Proctor RAL. Role of antibody in the prevention and pathogenesis of endotoxin and gram-negative shock. In: Proctor RA, ed. *Handbook of endotoxin*. Vol IV. Amsterdam: Elsevier, 1986: 161-184.
48. Ziegler EJ, McCutchan JA, Fierer J, et al. Treatment of gram-negative bacteremia and shock with human antiserum to a mutant *Escherichia coli*. *N Engl J Med* 1982; **307**:1225-1230.
49. Lachman E, Pitsoe SB, Gaffin S. Antilipopolysaccharide immunotherapy in management of septic shock of obstetric and gynaecological origin. *Lancet* 1984; **1**:981-983.
50. Teng NNH, Kaplan HS, Herbert JM, et al. Protection against gram-negative bacteremia and endotoxemia with human monoclonal IgM antibodies. *Proc Natl Acad Sci U S A* 1985; **82**:1790-1794.
51. Ziegler EJ, Fisher CJ, Sprung CL, et al. Treatment of gram-negative bacteremia and septic shock with HA-1A human monoclonal antibody against endotoxin. *N Engl J Med* 1991; **324**:429-436.
52. Gorelick K, Scannon PJ, Hannigen J, Wedel N, Ackerman SK. Randomized placebo-controlled study of E5 monoclonal anti-endotoxin antibody. In: Lauick J, Boueбалck L, eds. *Therapeutic monoclonal antibodies*. New York: Stockton Press, 1990: 253-261.
53. Wenzel RP, Bone R, Fein A, et al. Results of a second double-blind randomized, controlled trial of antiendotoxin antibody E5 in gram negative sepsis. American Society for Microbiology. 31st Interscience Conference on Antimicrobial Agents and Chemotherapy (ICAAC). 1991; **A1770**:294.
54. Bauss F, Droge W, Mannel DN. Tumor necrosis factor mediates endotoxic effects in mice. *Infect Immun* 1987; **55**:1622-1625.
55. Remick DG, Kunkel RG, Lauick JW, Kunkel SL. Acute in vivo effects of human recombinant tumor necrosis factor. *Lab Invest* 1987; **56**:583-590.
56. Silva AT, Bayston KF, Cohen J. Prophylactic and therapeutic effects of a monoclonal antibody to tumor necrosis factor in experimental gram-negative shock. *J Inf Dis* 1990; **162**:421-427.
57. Tracey KJ, Fong Y, Hesse DG, et al. Anti-cachectin/TNF monoclonal antibodies prevent septic shock during lethal bacteremia. *Nature* 1987; **330**:662-664.
58. Hinshaw LB, Tekamp-Olson P, Chang ACK, et al. Survival of primates in LD<sub>100</sub> septic shock following therapy with antibody to tumor necrosis factor (TNF). *Circ Shock* 1990; **30**:279-292.
59. Exley AR, Cohen J, Buurman W, et al. Monoclonal antibody to TNF in severe septic shock. *Lancet* 1990; **335**:1275-1277.
60. Casey L, Balk R, Simpson S, et al. Plasma tumor necrosis factor, interleukin-1 beta, and endotoxin in patients with sepsis. *Progress in Leukocyte Biology* 1990; **10B**:37-42.
61. Cannon JG, Tompkins RG, Gelfond JA, et al. Circulating interleukin-1 and tumor necrosis factor in septic shock and experimental endotoxin fever. *J Infect Dis* 1990; **161**:79-84.
62. Ohlsson K, Björk P, Bergenfeldt M, Hageman R, Thompson RC. Interleukin-1 receptor antagonist reduces mortality from endotoxin shock. *Nature* 1990; **348**:550-552.
63. McIntyre KW, Benjamin WR, Chizzonite RA, et al. Anti-interleukin-1 receptor antibody blocks inflammatory responses in vivo. *Progress in Leukocyte Biology* 1990; **10B**:435-440.
64. Gordon GS, Fisher CJ, Slotman GJ, et al. Cost-effectiveness of treatment with interleukin-1 receptor antagonist (IL-1ra) in patients with sepsis syndrome. *Clin Res* 1992; **40**(2):254A.
65. Chang SW, Feddersen CO, Hensen PM, Voelkel NF. Platelet activating factor mediates hemodynamic changes and lung injury in endotoxin-treated rats. *J Clin Invest* 1987; **79**:1498-1509.
66. Okamoto M, Yoshida K, Nishikawa M, Kohsaka M, Aoki H. Platelet activating factor (PAF) involvement in endotoxin induced thrombocytopenia in rabbits. Studies with FR-900452, a specific inhibitor of PAF. *Thromb Res* 1986; **42**:661-671.
67. Doebber TW, Wu MS, Robbins JC, MaChoy B, Chang MN, Shen TY. Platelet activating factor (PAF) involvement in endotoxin-induced hypotension in rats. Studies with PAF receptor antagonist kad-surenone. *Biochem Biophys Res Commun* 1985; **127**:799-808.
68. Casals-Stenzel J. Protective effect of WEB 2086, a novel antagonist of platelet activating factor in endotoxin shock. *Eur J Pharmacol* 1987; **135**:117-122.
69. Siebeck M, Weipert J, Keser C, et al. A triazolodiazepine platelet activating factor receptor antagonist (WEB2086) reduces pulmonary dysfunction during endotoxin shock in swine. *J Trauma* 1991; **31**:942-950.
70. Redl H, Vogl C, Schiesser A, et al. Effect of the PAF antagonist BN52021 in ovine endotoxin shock. *J Lipid Mediat* 1990; **(2 Suppl)**:S195-S201.
71. Terashita Z, Kawamura M, Takatani M, Tsushima S, Imura Y, Nishikawa K. Beneficial effect of TCV-309, a novel potent and selective platelet activating factor antagonist in endotoxin and anaphylactic shock in rodents. *J Pharmacol Exp Ther* 1992; **260**:748-755.
72. O'Flaherty JT, Thomas MJ, Cousart SL, Salzer WL, McCall CE. Neurotopenia induced by systemic infusion of 5,12-dihydroxy-6,8,10,14-eicosatetraenoic acid. *J Clin Invest* 1982; **69**:993-998.
73. Casey L, Clarke J, Fletcher J, Ramwell P. Cardiovascular, respiratory and hematological effects of leukotriene D<sub>4</sub> in primates. In: Samuelsson B, Paoletti R, editors. *Leukotrienes and other lipoxygenase products*. New York: Raven Press, 1982:201-210.
74. Dahlen SE, Bjork J, Hedquist P, et al. Leukotrienes promote plasma leakage and leukocyte adhesion in post capillary venules: in vivo effects with relevance to the acute inflammatory response. *Proc Natl Acad Sci* 1981; **78**:3887-3891.
75. Drazen JM, Austen KF, Lewis RA, et al. Comparative airway and vascular activities of leukotrienes C-1 and D in vivo and in vitro. *Proc Natl Acad Sci* 1980; **77**:4354-4358.
76. Ogletree MC, Oates JA, Brigham KL, Hubbard WC. Evidence for pulmonary release of 5-hydroxyeicosatetraenoic acid (5-HETE) during endotoxemia in unanesthetized sheep. *Prostaglandins* 1982; **2**:459-468.
77. Craft DV, Lefer DJ, Hock CE, Lefer AM. Significance of production of peptide leukotrienes in murine traumatic shock. *Am J Physiol: Heart Circ Physiol* 1986; **20**:H80-H85.
78. Smith EF, Kinter LB, Jugus M, Wasserman MA, Eckardt RD, Newton JF. Beneficial effects of the peptidoleukotriene receptor antagonist, SKF 104353 on the responses to experimental endotoxemia in the conscious rat. *Circ Shock* 1988; **25**:21-31.
79. Hayman W, Denzlinger C, Keppler D. Production of peptide leukotrienes in endotoxin shock. *FEBS Lett* 1985; **180**:309-313.
80. Etemudi AR, Tempel GE, Farah BA, Wise WC, Halushka PV, Cook JA. Beneficial effects of a leukotriene antagonist on endotoxin-induced acute hemodynamic alterations. *Circ Shock* 1987; **22**:55-63.
81. Cook JA, Wise WC, Halushka PV. Protective effect of a selective leukotriene antagonist in endotoxemia in the rat. *J Pharmacol Exp Ther* 1985; **235**:470-474.
82. Hall-Angeras M, Saljo A, Hasselgren PO. Effect of methylprednisolone, indomethacin and diethylcarbamazine on survival rate following trauma and sepsis in rats. *Circ Shock* 1986; **20**:231-238.
83. Petros A, Bennett D, Vallance P. Effect of nitric oxide synthase inhibitors on hypotension in patients with septic shock. *Lancet* 1991; **338**:1557-1558.
84. Nova E, Palmer RM, Moncada S. Inhibition of nitric oxide synthesis in septic shock: how much is beneficial? *Lancet* 1991; **338**:1555-1557.
85. Klabunde RE, Ritger RC. N<sup>G</sup>-Monomethyl-L-arginine (NMA) restores arterial blood pressure but reduces cardiac output in a canine model of endotoxin shock. *Biochem Biophys Res Commun* 1991; **178**:1135-1140.

86. Golenbock D, Leggett J, Rasmussen P, Craig W, Raetz C, Protor W. Lipid X protects mice against fatal *Escherichia coli* infection. *Infect Immun* 1988; **56**:779-784.
87. Chase JJ, Kubey W, Dulek MH, et al. Effect of monophosphoryl lipid A on host resistance to bacterial infection. *Infect Immun* 1986; **53**:711-712.
88. Astiz ME, Rackow EC, Kim YB, Weil MH. Monophosphoryl lipid A induces tolerance to lethal hemodynamic effects of endotoxemia. *Circ Shock* 1991; **33**:92-97.
89. Golenbock DT, Hampton RY, Qureshi N, Takayama K, Raetz CR. Lipid A-like molecules that antagonize the effects of endotoxins on human monocytes. *J Biol Chem* 1991; **266**:19490-19498.
90. Toumanen EI, Saukkonen K, Sande S, Cioffe C, Wright SD. Reduction of inflammation, tissue damage, and mortality in bacterial meningitis in rabbits treated with monoclonal antibodies against adhesion-promoting receptors of leukocytes. *J Exp Med* 1989; **170**:959-969.

